

2000 PSI DUCTILE IRON BALL VALVE



DIBV - TANK VALVE

FIG.# 4E-420DF3-T-FP/RP

Lever Operated, Threaded
 Floating Ball, RPTFE/DELTRIN Seat
 1000/1500/2000 W.O.G.
 Blow-Out Proof Stem
 Fire Safe Design
 Rugged Locking Device
 Grease Fitting
 NACE MR-0175 Compliant
 Inspect and Test: API 598

Nominal Pressure	2000	PSI
Shell Test (by Water)	3000	
Seal Test (by Water)	2200	
Seal Test (by Air)	60 ~ 100	
Threads conforms to	ANSI B1.20.1 BS21 DN 259/2999	
Temperature Range	-10°C (14°F) ~ 80°C (176°F)	

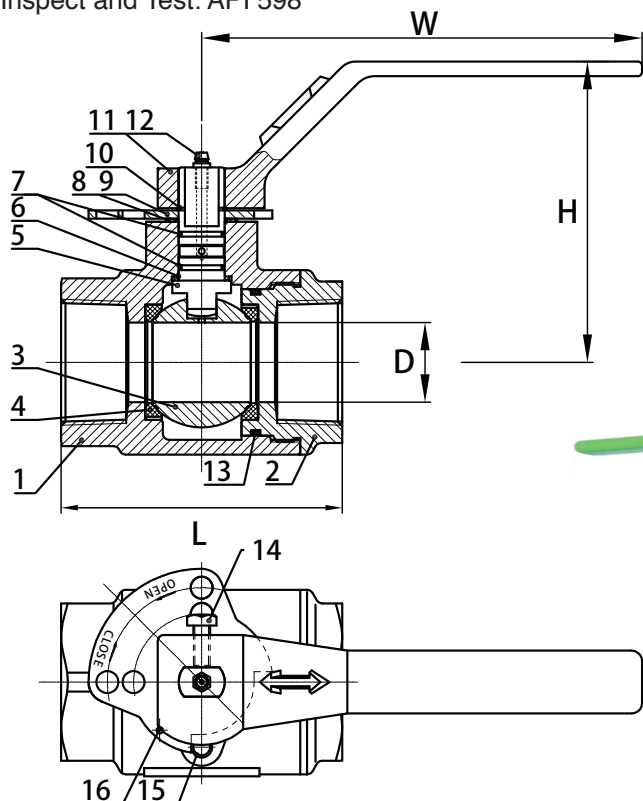

MATERIAL LIST

No.	Part Name	Material
1.	Body	A395
2.	Bonnet	A395
3.	Ball	SS 304
4.	Seat	RPTFE
5.	Stem	SS 304
6.	Stem Washer	RPTFE
7.	Stem O-Ring	VITON
8.	Thrusting Bearing	PTFE
9.	Stop Collar	A194 2H
10.	Snap Ring	6150
11.	Handle	WCB
12.	Grease Zerk	SS 420
13.	Body Seal	VITON
14.	Handle Screw	Steel
15.	Stop Bolt	Steel
16.	Pin with Screw	Copper & Steel

DIMENSIONS & WEIGHT

SIZE	unit	3/4" FP DIBVFP20 2000 PSI	1" FP DIBVFP25 2000 PSI	1" RP DIBVRP25 2000 PSI	1-1/2" FP DIBVFP40 2000 PSI	2" FP DIBVFP50 2000 PSI	2" RP DIBVRP50 2000 PSI	2-1/2" FP DIBVFP65 2000 PSI	3" FP DIBVFP80 2000 PSI	3" RP DIBVRP80 2000 PSI	4" FP DIBVFP100 2000 PSI	4" RP DIBVRP100 2000 PSI
D	inch	0.79	1.00	0.79	1.50	2.00	1.50	2.52	3.00	2.00	3.94	3.00
	mm	20	25	20	38	51	38	64	76	51	100	76
L	inch	3.78	4.00	3.78	5.50	6.02	5.50	7.00	8.74	7.28	9.40	8.74
	mm	96	102	96	140	153	140	178	222	185	239	222
W	inch	6.25	6.25	6.25	8.28	10.63	8.28	10.63	15.00	10.63	15.00	15.00
	mm	159	159	159	210	270	210	270	380	270	380	380
H	inch	3.07	3.19	3.07	5.67	5.87	5.67	6.14	7.05	5.87	7.80	7.05
	mm	78	81	78	144	149	144	156	179	149	198	179
WT.	lbs.	4.05	4.41	3.97	9.92	16.76	10.89	20.94	42.99	18.96	54.90	40.79
	kgs.	1.84	2	1.8	4.5	7.6	4.94	9.5	19.5	8.6	24.9	18.5

Weights are approximate and construction is subject to change without notice.